

Operating Stand Included with Shipment



Width 53 cm (21 in.) **Depth** 75 cm (29 in.) **Height** 64 cm (25 in.)

AL300 weighs 115 kg (255 lbs) with Change Part set installed. Included is a specially designed stand with a height that allows for easy addition of capsules to Hopper on top of Orienter. Stand is on lockable wheels for easy movement. Stand has an open area under Orienter to allow for access to the underside of the machine for maintenance and cleaning.

Required clearance height above table: 112 cm (44 in.).

Recommendations for Other Operating Tables

- Width** 195 cm (77 in.) if Filler and Orienter are operated on same table.
- 163 cm (64 in.) if Filler and Orienter are operated on same table but Locked Capsule Bin is removed.
- 76 cm (30 in) if Orienter is operated on separate table.
- Depth** 79 cm (31 in.) minimum.
- Height** 61-74 cm (24 - 29 in.)

Product Weight & Dimensions

Orienter fitted with Change Parts

115 kg
255 lbs

Operating Stand

25 kg
55 lbs

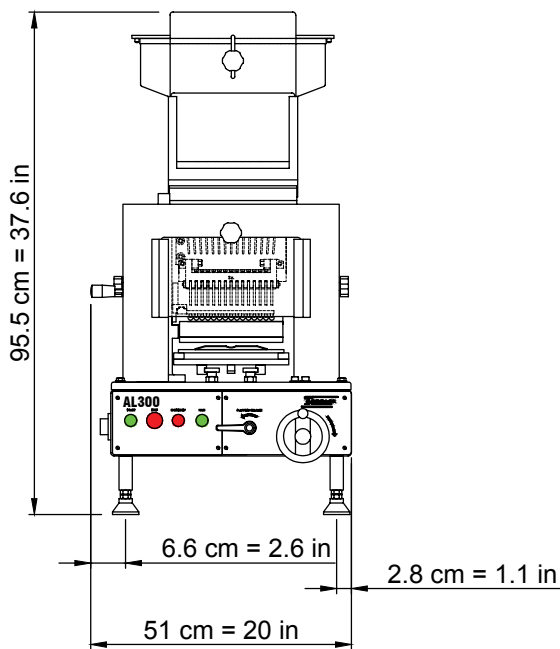

FRONT VIEW

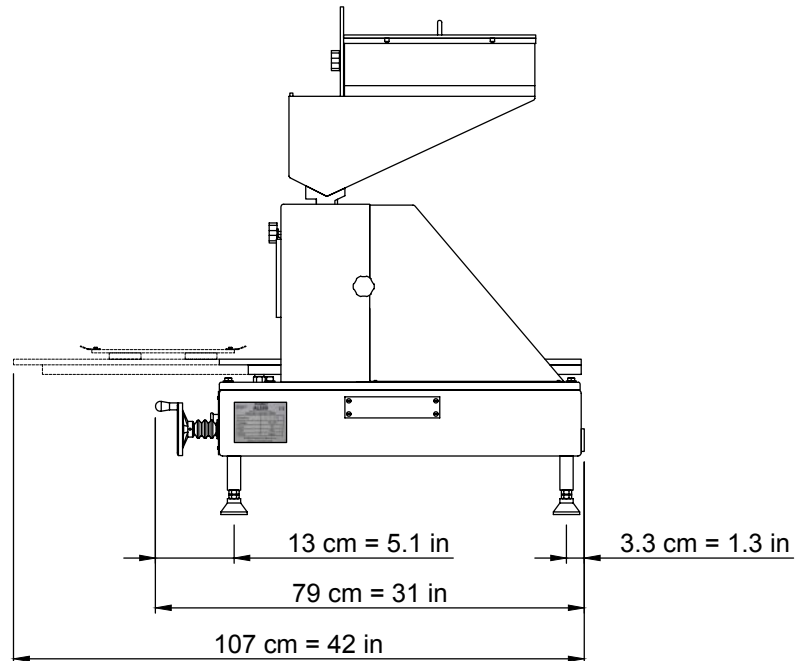

SIDE VIEW